

用途 Applications

主要用于大、中型水厂或污水处理厂中混凝剂药剂溶解。

The Agitator is mainly used for the dissolve of agents such as coagulants in large-and medium-scale water plants or sewage treatment plants.

外形及尺寸 Shape and Size

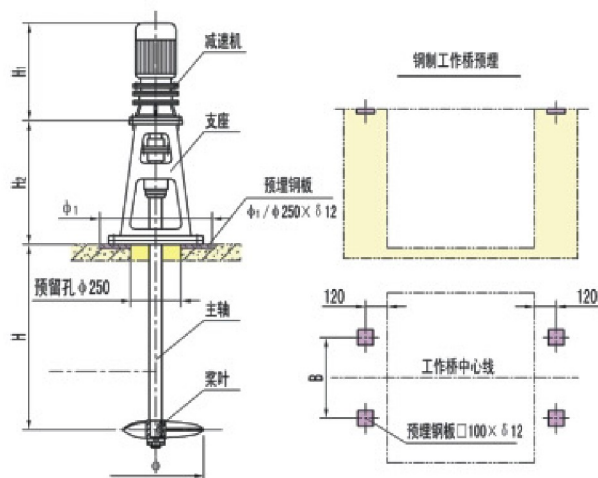

型号示例 Type and Its Indication

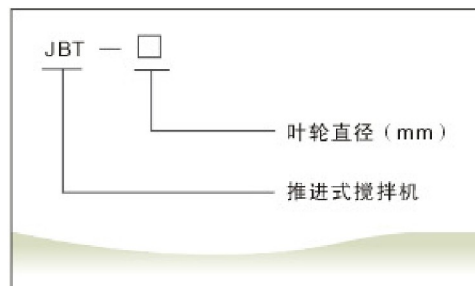

型号	参数	JBT300	JBT500	JBT700
转速 (r/min)		136	136	136
功率 (kW)		2.2	3	5.5
外型尺寸 (mm)	Φ	Φ300	Φ500	Φ700
	H	~1800	~2200	~3000
	H ₁	~630	~630	~630
	H ₂	536	586	586
	B	500	550	550
适用池型 (mm)	Φ ₁	460	Φ500	Φ550
		□1400 Φ1400	□1800 Φ1800	□2500 Φ2500

订货说明 Requirements for Order

1. 注明水深及池形尺寸。
2. 注明水下部件的材质（碳钢或不锈钢）。
3. 本机不包括工作桥，需要时请注明。
4. 需要配调速减速机时，请注明速度范围。

1. Note the depth of water and the outline and dimension of the tank.
2. Note material (carbon steel or stainless steel), of which underwater parts are made.
3. The Agitator doesn't consist of working bridge. When the bridge is needed, note that.
4. Note should be made when the speed variation reducer is need. Please specify the speed variation range.

搅拌机常用桨叶类型 The Usually Impeller Type of The Agitator

