



● 用途 Applications

YJ型药物搅拌机有两种安装形式：移动式和固定式。移动式可在竖直、倾角 30° 内调节。两种搅拌机均采用电机直接驱动，速度有 750 和 1500r/min 两种，结构简单，重量轻，适用于较小池形的药物溶解，池内可设置挡板，以增加搅拌效果。水下部件（轴、桨叶等）可用不锈钢材质制造。

There are two kinds of the installation of the Agitator: mobile and fixed. The mobile type can be adjusted within a angle between vertical and dip angle of 30 degrees. Motors, whose rate is 750 rpm or 1500rpm, directly drive both agitators. The Agitator is with simple structure and low weight, and applied to the dissolving of chemical in small-sized tank. The retaining boards can be set in the tank to strengthen mixing. The underwater parts (shaft, oars, and etc.) may be made of stainless steel.

● 型号示例 Type and Its Indication

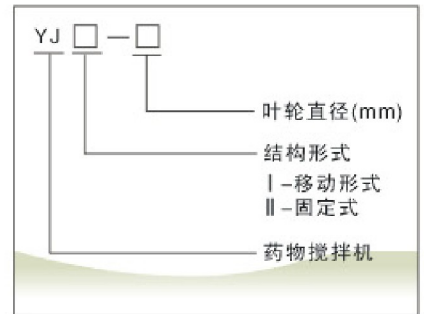

● YJ I 型外形尺寸与参数表

Type YJ I Shape and Size Parameters

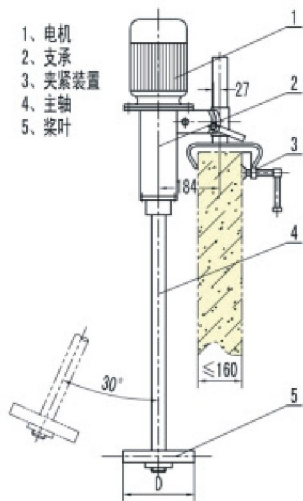

● YJ II 型外形尺寸与参数表

Type YJ II Shape and Size Parameters

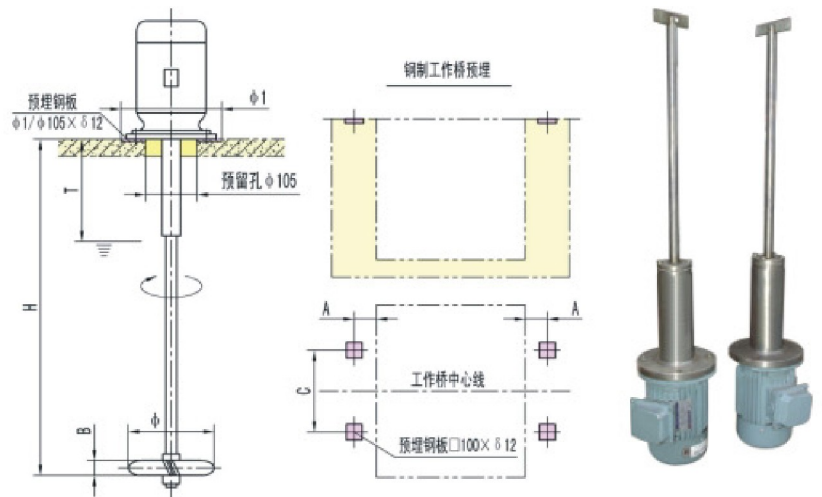

型号	YJ I - 105
参数	
浆板长度 (mm)	105
转速 (r/min)	1500
功率 (kW)	0.75
适用池子尺寸	□ 800 × 1100 Φ 800 × 1100

型号	YJ II - 80	YJ II - 128		YJ II - 160	
参数					
浆叶直径 Φ (mm)	Φ 80	Φ 128		Φ 160	
搅拌转速 (r/min)	750	750	1500	750	1500
搅拌功率 (kW)	0.37	0.55	1.1	1.1	2.2
H	≤ 1000	≤ 1000	≤ 1250	≤ 1250	≤ 1250
T	200	200	200	200	200
C	250	250	250	250	300
A	80	80	80	80	100
Φ 1	250	250	250	250	300